

<b>EN</b>	Cordless Inflator	INSTRUCTION MANUAL	4
<b>FR</b>	Gonfleur sans fil	MANUEL D'INSTRUCTIONS	12
<b>DE</b>	Akku Kompressor	BETRIEBSANLEITUNG	21
<b>IT</b>	Gonfiatore a batteria	ISTRUZIONI PER L'USO	31
<b>NL</b>	Acculuchtpomp	GEBRUIKSAANWIJZING	41
<b>ES</b>	Inflador Inalámbrico	MANUAL DE INSTRUCCIONES	51
<b>PT</b>	Compressor a Bateria	MANUAL DE INSTRUÇÕES	61
<b>DA</b>	Akku pumpe	BRUGSANVISNING	70
<b>EL</b>	Φορητή τρόμππα	ΕΓΧΕΙΡΙΔΙΟ ΟΔΗΓΙΩΝ	78
<b>TR</b>	Akülü Hava Pompası	KULLANMA KILAVUZU	88
<b>SV</b>	Batteridrivnen uppblåsningssenhet	BRUKSANVISNING	96
<b>NO</b>	Trådløs pumpe	BRUKSANVISNING	104
<b>FI</b>	Akkukäyttöinen täyttöpumppu	KÄYTTÖOHJE	112
<b>LV</b>	Bezvadu pumpis	LIETOŠANAS INSTRUKCIJA	120
<b>LT</b>	Belaidė pompa	NAUDOJIMO INSTRUKCIJA	129
<b>ET</b>	Juhtmeta täispuhuja	KASUTUSJUHEND	137
<b>PL</b>	Minikompresor akumulatorowy	INSTRUKCJA OBSŁUGI	145
<b>HU</b>	Akkumulátoros pumpa	HASZNÁLATI KÉZIKÖNYV	155
<b>SK</b>	Akkumulátorový kompresor	NÁVOD NA OBSLUHU	164
<b>CS</b>	Akkumulátorový kompresor	NÁVOD K OBSLUZE	173
<b>SL</b>	Akkumulatorska zračna tlačilka	NAVODILA ZA UPORABO	181
<b>SQ</b>	Pompë me bateri	MANUALI I PËRDORIMIT	189
<b>BG</b>	Акумулаторен компресор	РЪКОВОДСТВО ЗА ЕКСПЛОАТАЦИЯ	198
<b>HR</b>	Bežični uređaj za napuhavanje	PRIRUČNIK S UPUTAMA	208
<b>MK</b>	Безжичен компресор	УПАТСТВО ЗА УПОТРЕБА	216
<b>SR</b>	Безжична пумпа	УПУТСТВО ЗА УПОТРЕБУ	226
<b>RO</b>	Compresor cu acumulator	MANUAL DE INSTRUCȚIUNI	235
<b>UK</b>	Акумуляторний насос	ІНСТРУКЦІЯ З ЕКСПЛУАТАЦІЇ	244
<b>RU</b>	Акумуляторный Насос	РУКОВОДСТВО ПО ЭКСПЛУАТАЦИИ	254
<b>KK</b>	Акумуляторлы сорғысы	ПАЙДАЛАНУ ЖӨНІНДЕГІ НҮСҚАУЛЫҚ	264
<b>ZHTW</b>	充電式打氣機	使用說明書	274
<b>FA</b>		پمپ باد شارژی	دفتريچه راهنما 288
<b>AR</b>		المنفاخ اللاسلكي	دليل الإرشادات 295

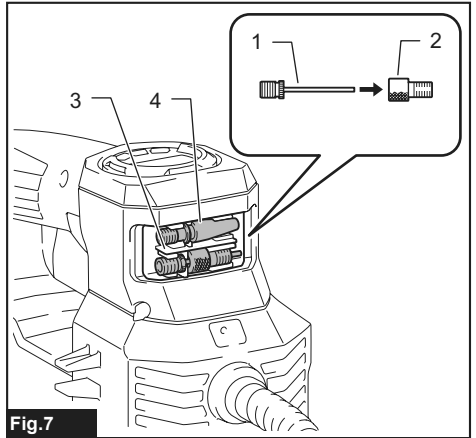

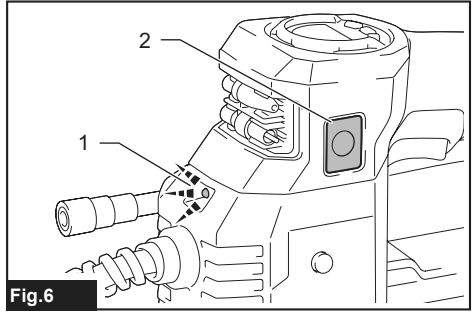

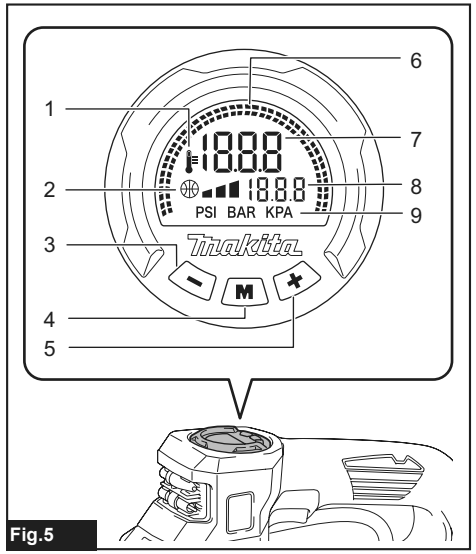
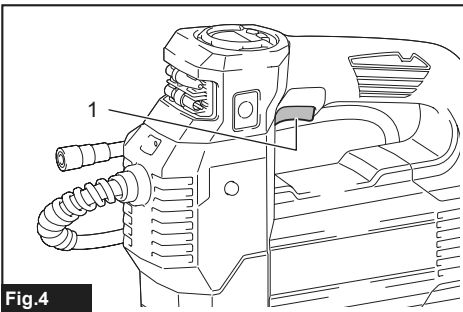
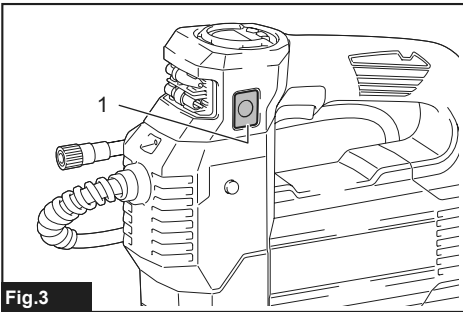
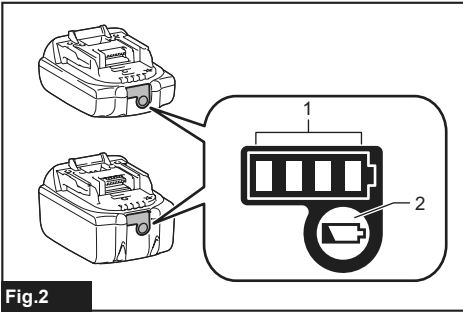
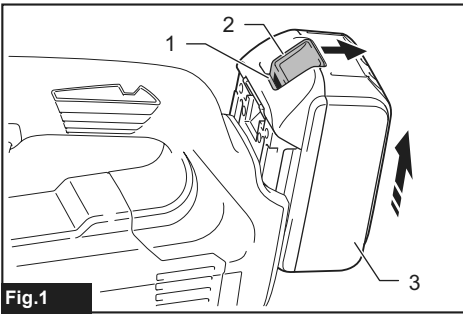
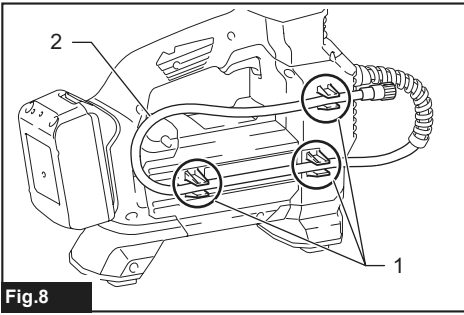

Fig.8

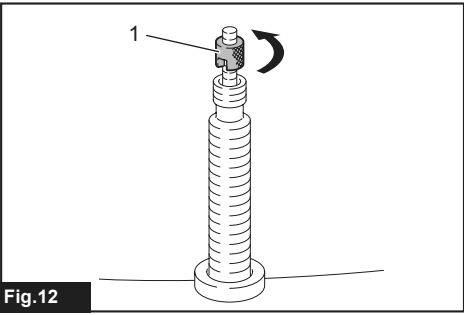

Fig.12

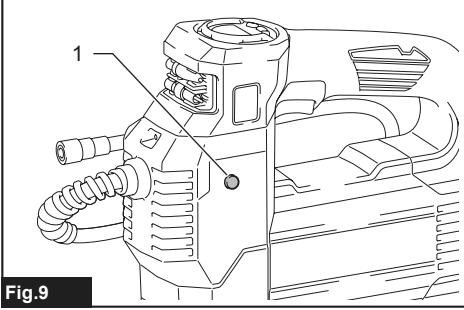

Fig.9

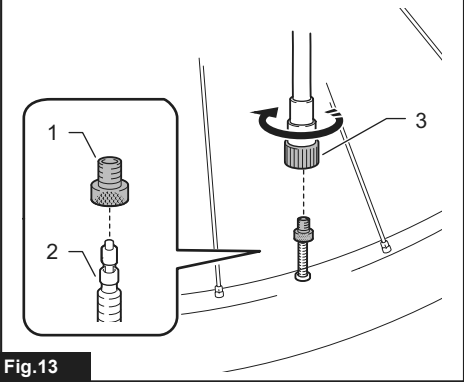

Fig.13

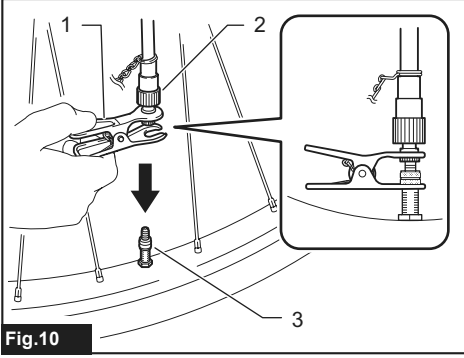

Fig.10

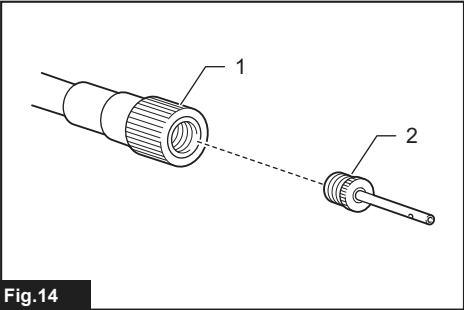

Fig.14

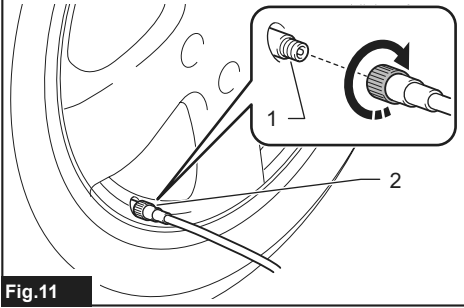

Fig.11

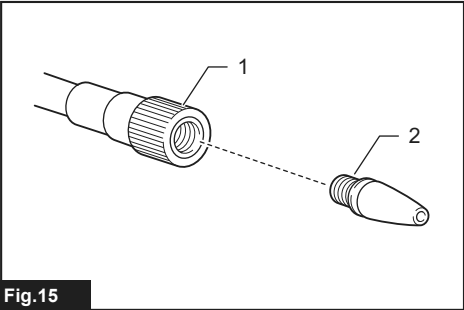

Fig.15

# SPECIFICATIONS

<b>Model:</b>		<b>DMP181</b>
Overall length	with BL1815N	297 mm
	with BL1860B	316 mm
Maximum air pressure		1,110 kPa
Duty cycle		10 minutes On / 5 minutes Off
Rated voltage		D.C. 18 V
Net weight		2.5 - 2.8 kg

- Due to our continuing program of research and development, the specifications herein are subject to change without notice.
- Specifications and battery cartridge may differ from country to country.
- The weight may differ depending on the attachment(s), including the battery cartridge. The lightest and heaviest combinations, according to EPTA-Procedure 01/2014, are shown in the table.

## Applicable battery cartridge and charger

Battery cartridge	BL1815N / BL1820B / BL1830B / BL1840B / BL1850B / BL1860B
Charger	DC18RC / DC18RD / DC18RE / DC18SD / DC18SE / DC18SF / DC18SH

- Some of the battery cartridges and chargers listed above may not be available depending on your region of residence.

**⚠ WARNING: Only use the battery cartridges and chargers listed above.** Use of any other battery cartridges and chargers may cause injury and/or fire.

## Symbols

The followings show the symbols which may be used for the equipment. Be sure that you understand their meaning before use.



Read instruction manual.



Risk of bursting.



Only for EU countries  
 Due to the presence of hazardous components in the equipment, waste electrical and electronic equipment, accumulators and batteries may have a negative impact on the environment and human health. Do not dispose of electrical and electronic appliances or batteries with household waste!  
 In accordance with the European Directive on waste electrical and electronic equipment and on accumulators and batteries and waste accumulators and batteries, as well as their adaptation to national law, waste electrical equipment, batteries and accumulators should be stored separately and delivered to a separate collection point for municipal waste, operating in accordance with the regulations on environmental protection.  
 This is indicated by the symbol of the crossed-out wheeled bin placed on the equipment.

## Intended use

This tool is intended for inflating tire, sport ball, or small floating tube.

## Noise

The typical A-weighted noise level determined according to EN62841-1:  
 Sound pressure level ( $L_{pA}$ ) : 70 dB(A)  
 Uncertainty (K) : 3 dB(A)

The noise level under working may exceed 80 dB (A).

**NOTE:** The declared noise emission value(s) has been measured in accordance with a standard test method and may be used for comparing one tool with another.

**NOTE:** The declared noise emission value(s) may also be used in a preliminary assessment of exposure.

**⚠ WARNING:** Wear ear protection.

**⚠ WARNING:** The noise emission during actual use of the power tool can differ from the declared value(s) depending on the ways in which the tool is used especially what kind of workpiece is processed.

**⚠ WARNING:** Be sure to identify safety measures to protect the operator that are based on an estimation of exposure in the actual conditions of use (taking account of all parts of the operating cycle such as the times when the tool is switched off and when it is running idle in addition to the trigger time).

## Vibration

The vibration total value (tri-axial vector sum) determined according to EN62841-1:

Work mode: Inflating (1,110 kPa)

Vibration emission ( $a_w$ ): 3.6 m/s<sup>2</sup>

Uncertainty (K): 1.5 m/s<sup>2</sup>

**NOTE:** The declared vibration total value(s) has been measured in accordance with a standard test method and may be used for comparing one tool with another.

**NOTE:** The declared vibration total value(s) may also be used in a preliminary assessment of exposure.

**⚠ WARNING:** The vibration emission during actual use of the power tool can differ from the declared value(s) depending on the ways in which the tool is used especially what kind of workpiece is processed.

**⚠ WARNING:** Be sure to identify safety measures to protect the operator that are based on an estimation of exposure in the actual conditions of use (taking account of all parts of the operating cycle such as the times when the tool is switched off and when it is running idle in addition to the trigger time).

## EC Declaration of Conformity

### *For European countries only*

The EC declaration of conformity is included as Annex A to this instruction manual.

# SAFETY WARNINGS

## General power tool safety warnings

**⚠ WARNING:** Read all safety warnings, instructions, illustrations and specifications provided with this power tool. Failure to follow all instructions listed below may result in electric shock, fire and/or serious injury.

## Save all warnings and instructions for future reference.

The term "power tool" in the warnings refers to your mains-operated (corded) power tool or battery-operated (cordless) power tool.

### Work area safety

1. **Keep work area clean and well lit.** Cluttered or dark areas invite accidents.
2. **Do not operate power tools in explosive atmospheres, such as in the presence of flammable liquids, gases or dust.** Power tools create sparks which may ignite the dust or fumes.
3. **Keep children and bystanders away while operating a power tool.** Distractions can cause you to lose control.

### Electrical safety

1. **Power tool plugs must match the outlet. Never modify the plug in any way. Do not use any adapter plugs with earthed (grounded) power tools.** Unmodified plugs and matching outlets will reduce risk of electric shock.
2. **Avoid body contact with earthed or grounded surfaces, such as pipes, radiators, ranges and refrigerators.** There is an increased risk of electric shock if your body is earthed or grounded.
3. **Do not expose power tools to rain or wet conditions.** Water entering a power tool will increase the risk of electric shock.
4. **Do not abuse the cord. Never use the cord for carrying, pulling or unplugging the power tool. Keep cord away from heat, oil, sharp edges or moving parts.** Damaged or entangled cords increase the risk of electric shock.
5. **When operating a power tool outdoors, use an extension cord suitable for outdoor use.** Use of a cord suitable for outdoor use reduces the risk of electric shock.
6. **If operating a power tool in a damp location is unavoidable, use a residual current device (RCD) protected supply.** Use of an RCD reduces the risk of electric shock.
7. **Power tools can produce electromagnetic fields (EMF) that are not harmful to the user.** However, users of pacemakers and other similar medical devices should contact the maker of their device and/or doctor for advice before operating this power tool.

### Personal safety

1. **Stay alert, watch what you are doing and use common sense when operating a power tool. Do not use a power tool while you are tired or under the influence of drugs, alcohol or medication.** A moment of inattention while operating power tools may result in serious personal injury.
2. **Use personal protective equipment. Always wear eye protection.** Protective equipment such as a dust mask, non-skid safety shoes, hard hat or hearing protection used for appropriate conditions will reduce personal injuries.

3. **Prevent unintentional starting.** Ensure the switch is in the off-position before connecting to power source and/or battery pack, picking up or carrying the tool. Carrying power tools with your finger on the switch or energising power tools that have the switch on invites accidents.
4. **Remove any adjusting key or wrench before turning the power tool on.** A wrench or a key left attached to a rotating part of the power tool may result in personal injury.
5. **Do not overreach. Keep proper footing and balance at all times.** This enables better control of the power tool in unexpected situations.
6. **Dress properly. Do not wear loose clothing or jewellery. Keep your hair and clothing away from moving parts.** Loose clothes, jewellery or long hair can be caught in moving parts.
7. **If devices are provided for the connection of dust extraction and collection facilities, ensure these are connected and properly used.** Use of dust collection can reduce dust-related hazards.
8. **Do not let familiarity gained from frequent use of tools allow you to become complacent and ignore tool safety principles.** A careless action can cause severe injury within a fraction of a second.
9. **Always wear protective goggles to protect your eyes from injury when using power tools. The goggles must comply with ANSI Z87.1 in the USA, EN 166 in Europe, or AS/NZS 1336 in Australia/New Zealand. In Australia/New Zealand, it is legally required to wear a face shield to protect your face, too.**
3. **Disconnect the plug from the power source and/or remove the battery pack, if detachable, from the power tool before making any adjustments, changing accessories, or storing power tools.** Such preventive safety measures reduce the risk of starting the power tool accidentally.
4. **Store idle power tools out of the reach of children and do not allow persons unfamiliar with the power tool or these instructions to operate the power tool.** Power tools are dangerous in the hands of untrained users.
5. **Maintain power tools and accessories. Check for misalignment or binding of moving parts, breakage of parts and any other condition that may affect the power tool's operation. If damaged, have the power tool repaired before use.** Many accidents are caused by poorly maintained power tools.
6. **Keep cutting tools sharp and clean.** Properly maintained cutting tools with sharp cutting edges are less likely to bind and are easier to control.
7. **Use the power tool, accessories and tool bits etc. in accordance with these instructions, taking into account the working conditions and the work to be performed.** Use of the power tool for operations different from those intended could result in a hazardous situation.
8. **Keep handles and grasping surfaces dry, clean and free from oil and grease.** Slippery handles and grasping surfaces do not allow for safe handling and control of the tool in unexpected situations.
9. **When using the tool, do not wear cloth work gloves which may be entangled.** The entanglement of cloth work gloves in the moving parts may result in personal injury.

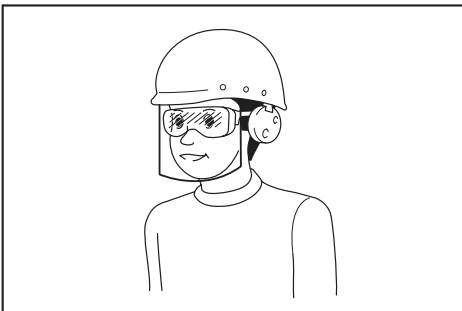

It is an employer's responsibility to enforce the use of appropriate safety protective equipments by the tool operators and by other persons in the immediate working area.

#### Power tool use and care

1. **Do not force the power tool. Use the correct power tool for your application.** The correct power tool will do the job better and safer at the rate for which it was designed.
2. **Do not use the power tool if the switch does not turn it on and off.** Any power tool that cannot be controlled with the switch is dangerous and must be repaired.
1. **Recharge only with the charger specified by the manufacturer.** A charger that is suitable for one type of battery pack may create a risk of fire when used with another battery pack.
2. **Use power tools only with specifically designated battery packs.** Use of any other battery packs may create a risk of injury and fire.
3. **When battery pack is not in use, keep it away from other metal objects, like paper clips, coins, keys, nails, screws or other small metal objects, that can make a connection from one terminal to another.** Shorting the battery terminals together may cause burns or a fire.
4. **Under abusive conditions, liquid may be ejected from the battery; avoid contact. If contact accidentally occurs, flush with water. If liquid contacts eyes, additionally seek medical help.** Liquid ejected from the battery may cause irritation or burns.
5. **Do not use a battery pack or tool that is damaged or modified.** Damaged or modified batteries may exhibit unpredictable behaviour resulting in fire, explosion or risk of injury.
6. **Do not expose a battery pack or tool to fire or excessive temperature.** Exposure to fire or temperature above 130 °C may cause explosion.

7. **Follow all charging instructions and do not charge the battery pack or tool outside the temperature range specified in the instructions.** Charging improperly or at temperatures outside the specified range may damage the battery and increase the risk of fire.
- Service**
1. **Have your power tool serviced by a qualified repair person using only identical replacement parts.** This will ensure that the safety of the power tool is maintained.
  2. **Never service damaged battery packs.** Service of battery packs should only be performed by the manufacturer or authorized service providers.
  3. **Follow instruction for lubricating and changing accessories.**

## Cordless inflator safety warnings

1. **When inflating objects, connect the air chuck, adapter, and valve tightly.** Otherwise, the object, hose, air chuck, or adapter may be damaged and you may be injured.
2. **Release air pressure slowly. When removing the hose after inflating objects, hold the object, hose, and air chuck firmly.** The object, air chuck, or adapter may bounce due to exhaust air and cause an injury.
3. **Do not inflate object beyond the maximum pressure of the object.** Otherwise, the tool or object may be damaged and you may be injured.
4. **Do not use the tool beyond the maximum output pressure of the tool.** Using the tool at output pressure greater than the maximum output pressure of the tool may burst the object or the tool.
5. **Inflate the objects intended to be inflated by the manufacturer only, such as tire, sport ball, or small floating tube.** Inflating other objects may damage them and cause an injury.
6. **When inflating objects, check the pressure gauge, status of the tool and object, and check that there is no air leak.** Otherwise, the tool or object may be damaged and cause an injury.
7. **When carrying the tool, hold the handle of the tool. Do not hold or pull the hose.** The tool may be damaged and cause an injury.
8. **After inflating objects, check the air pressure using a reliable and calibrated measuring equipment.** Use the pressure gauge of the tool only as a reference.
9. **After using the tool for 10 minutes continuously, stop using the tool for 5 minutes for cooling down. Do not use the tool beyond the continuous operating time allowed.** Otherwise, the tool may be damaged and cause an injury.
10. **Do not use the tool on sand or dusty surface.** Foreign objects may enter the inside of the tool and cause a malfunction.
11. **Do not point the outlet of the hose to yourself or others.** Objects may be blown away and cause an injury.
12. **Do not point the outlet of the hose to dust or similar.** The dust may be scattered and cause an injury.
13. **Do not inflate large capacity objects.** If you inflate a large capacity object, the tool may become extremely hot and could burn your skin.
14. **Do not touch the tool, hose, air chuck, or adapter right after inflating objects.** The metal parts may become extremely hot and could burn your skin.
15. **Do not use the tool with wet hands.**
16. **Make sure that the hose is not entangled.** The entangled hose may cause loss of balance and cause an injury.
17. **Never leave the tool unattended when the hose is attached to the object or during operation.**
18. **Do not use the tool as a breathing device.**
19. **Do not use the tool to spray chemicals.** Your lungs may be damaged by inhaling toxic fumes.
20. **Operate the tool in an open area at least 50 cm away from any wall or object that could restrict air flow to ventilation openings.**
21. **Do not disassemble the tool.**
22. **Use only standard accessories provided by Makita.** The use of any other accessories or attachments might present a risk of injury to persons.
23. **Before you inflate a tire, make sure that there are no scratches or cracks in the tire.** Damaged tire can burst when it is inflated and cause an injury.
24. **While you inflate a tire, do not stay in front of its sidewall.**

## Important safety instructions for battery cartridge

1. **Before using battery cartridge, read all instructions and cautionary markings on (1) battery charger, (2) battery, and (3) product using battery.**
2. **Do not disassemble or tamper with the battery cartridge.** It may result in a fire, excessive heat, or explosion.
3. **If operating time has become excessively shorter, stop operating immediately.** It may result in a risk of overheating, possible burns and even an explosion.
4. **If electrolyte gets into your eyes, rinse them out with clear water and seek medical attention right away.** It may result in loss of your eyesight.
5. **Do not short the battery cartridge:**
  - (1) **Do not touch the terminals with any conductive material.**
  - (2) **Avoid storing battery cartridge in a container with other metal objects such as nails, coins, etc.**
  - (3) **Do not expose battery cartridge to water or rain.**

**A battery short can cause a large current flow, overheating, possible burns and even a breakdown.**
6. **Do not store and use the tool and battery cartridge in locations where the temperature may reach or exceed 50 °C (122 °F).**

7. **Do not incinerate the battery cartridge even if it is severely damaged or is completely worn out. The battery cartridge can explode in a fire.**
8. **Do not nail, cut, crush, throw, drop the battery cartridge, or hit against a hard object to the battery cartridge.** Such conduct may result in a fire, excessive heat, or explosion.
9. **Do not use a damaged battery.**
10. **The contained lithium-ion batteries are subject to the Dangerous Goods Legislation requirements.**  
For commercial transports e.g. by third parties, forwarding agents, special requirement on packaging and labeling must be observed.  
For preparation of the item being shipped, consulting an expert for hazardous material is required.  
Please also observe possibly more detailed national regulations.  
Tape or mask off open contacts and pack up the battery in such a manner that it cannot move around in the packaging.
11. **When disposing the battery cartridge, remove it from the tool and dispose of it in a safe place. Follow your local regulations relating to disposal of battery.**
12. **Use the batteries only with the products specified by Makita.** Installing the batteries to non-compliant products may result in a fire, excessive heat, explosion, or leak of electrolyte.
13. **If the tool is not used for a long period of time, the battery must be removed from the tool.**
14. **During and after use, the battery cartridge may take on heat which can cause burns or low temperature burns. Pay attention to the handling of hot battery cartridges.**
15. **Do not touch the terminal of the tool immediately after use as it may get hot enough to cause burns.**
16. **Do not allow chips, dust, or soil stuck into the terminals, holes, and grooves of the battery cartridge.** It may result in poor performance or breakdown of the tool or battery cartridge.
17. **Unless the tool supports the use near high-voltage electrical power lines, do not use the battery cartridge near high-voltage electrical power lines.** It may result in a malfunction or breakdown of the tool or battery cartridge.
18. **Keep the battery away from children.**

## SAVE THESE INSTRUCTIONS.

**⚠ CAUTION:** Only use genuine Makita batteries. Use of non-genuine Makita batteries, or batteries that have been altered, may result in the battery bursting causing fires, personal injury and damage. It will also void the Makita warranty for the Makita tool and charger.

## Tips for maintaining maximum battery life

1. **Charge the battery cartridge before completely discharged. Always stop tool operation and charge the battery cartridge when you notice less tool power.**
2. **Never recharge a fully charged battery cartridge. Overcharging shortens the battery service life.**
3. **Charge the battery cartridge with room temperature at 10 °C - 40 °C (50 °F - 104 °F). Let a hot battery cartridge cool down before charging it.**
4. **When not using the battery cartridge, remove it from the tool or the charger.**
5. **Charge the battery cartridge if you do not use it for a long period (more than six months).**

## FUNCTIONAL DESCRIPTION

**⚠ CAUTION:** Always be sure that the tool is switched off and the battery cartridge is removed before adjusting or checking function on the tool.

## Installing or removing battery cartridge

**⚠ CAUTION:** Always switch off the tool before installing or removing of the battery cartridge.

**⚠ CAUTION:** Hold the tool and the battery cartridge firmly when installing or removing battery cartridge. Failure to hold the tool and the battery cartridge firmly may cause them to slip off your hands and result in damage to the tool and battery cartridge and a personal injury.

► Fig.1: 1. Red indicator 2. Button 3. Battery cartridge

To remove the battery cartridge, slide it from the tool while sliding the button on the front of the cartridge.

To install the battery cartridge, align the tongue on the battery cartridge with the groove in the housing and slip it into place. Insert it all the way until it locks in place with a little click. If you can see the red indicator as shown in the figure, it is not locked completely.

**⚠ CAUTION:** Always install the battery cartridge fully until the red indicator cannot be seen. If not, it may accidentally fall out of the tool, causing injury to you or someone around you.

**⚠ CAUTION:** Do not install the battery cartridge forcibly. If the cartridge does not slide in easily, it is not being inserted correctly.



## Indicating the remaining battery capacity

Only for battery cartridges with the indicator

► Fig.2: 1. Indicator lamps 2. Check button

Press the check button on the battery cartridge to indicate the remaining battery capacity. The indicator lamps light up for a few seconds.

Indicator lamps			Remaining capacity
Lighted	Off	Blinking	
■	□	▧	75% to 100%
■	■	■	
■	■	□	50% to 75%
■	■	□	25% to 50%
■	□	□	0% to 25%
▧	□	□	Charge the battery.
■	■	□	The battery may have malfunctioned.
□	□	■	

**NOTE:** Depending on the conditions of use and the ambient temperature, the indication may differ slightly from the actual capacity.

**NOTE:** The first (far left) indicator lamp will blink when the battery protection system works.

## Tool / battery protection system

The tool is equipped with a tool/battery protection system. This system automatically cuts off the power to extend tool and battery life. The tool will automatically stop during operation if the tool or battery is placed under one of the following conditions:

### Overload protection

This protection works when the tool/battery is operated in a manner that causes it to draw an abnormally high current. In this situation, turn the tool off and stop the application that caused the tool to become overloaded. Then turn the tool on to restart.

### Overheat protection

This protection works when the tool/battery is overheated. The lamp blinks and the overheat warning icon is displayed on the pressure gauge. In this situation, turn the tool off and let the tool and battery cool down. Then, turn the tool on again.

### Overdischarge protection

This protection works when the remaining battery capacity gets low. In this situation, remove the battery from the tool and charge the battery.

## Main power switch

**WARNING:** Always turn off the main power switch when not in use.

**CAUTION:** When carrying the tool, turn off the main power switch. Otherwise, pulling the switch trigger unintentionally may cause an injury.

► Fig.3: 1. Main power switch

To turn on the tool, press the main power switch. To turn off the tool, press the main power switch again.

**NOTE:** This tool employs the auto power-off function. To avoid unintentional start up, the main power switch will automatically shut down when the switch trigger is not pulled for a certain period after the main power switch is turned on.

## Switch action

**WARNING:** Before installing the battery cartridge into the tool, always check to see that the switch trigger actuates properly and returns to the "OFF" position when released.

**WARNING:** Do not attach a tape or such to keep the switch trigger in the "ON" position.

To start the tool, simply pull the switch trigger. Release the switch trigger to stop.

► Fig.4: 1. Switch trigger

## Pressure gauge

► Fig.5

1	Overheat warning icon
2	Inflation mode
3	[-] button
4	[M] button
5	[+] button
6	Inflation progress indicator
7	Current pressure value
8	Target pressure value
9	Pressure value unit

If the object to be inflated is connected to the tool, the current pressure value of the object is displayed on the pressure gauge when you turn on the tool. If nothing is connected to the tool, the pressure gauge displays "0". The pressure gauge also displays the target pressure value, pressure value unit, and inflation mode. They are the same as the last time.

When you start inflation, the inflation progress indicator is displayed. The inflation completes when the inflation progress indicator comes to the right end.



## Setting the target pressure value

Press the [M] button, and select the pressure value unit. The pressure value unit is changed each time you press the [M] button. You can select one of the three units: PSI, BAR, or KPA.

To increase the target pressure value, press the [+] button. To decrease the target pressure value, press the [-] button. You can set the target pressure value between 35 kPa (5 PSI) and 1,110 kPa (161 PSI).

## Setting the inflation mode

Press the [M] button for 3 seconds. The inflation mode is changed each time you press and hold the [M] button. You can select one of the three modes as follows.

Mode	Display	Purpose	Adjustable pressure range
Ball		To inflate balls	35 to 110 kPa (5 to 16 PSI)
Low speed		To inflate objects in low speed	35 to 1,110 kPa (5 to 161 PSI)
High speed		To inflate objects in high speed	

**NOTE:** Be sure to select the ball mode when you inflate a ball using a sport ball needle. If other mode is selected, the inflation cannot be performed properly.

**NOTE:** Be sure to select the low speed mode when you inflate an object using an English valve adapter. If other mode is selected, the inflation cannot be performed properly.

## Lighting up the front lamp

When you turn on the tool by pressing the main power switch, the lamp lights up. When you turn off the tool by pressing the main power switch, the lamp goes out.

► **Fig.6:** 1. Lamp 2. Main power switch

**CAUTION:** Do not look in the light or see the source of light directly.

**NOTICE:** When the tool is overheated, the lamp blinks. Turn the tool off and let the tool cool down fully before operating the tool again.

**NOTE:** Use a dry cloth to wipe the dirt off the lens of the lamp. Be careful not to scratch the lens of lamp, or it may lower the illumination.

## Storing adapter

The adapters can be stored in the adapter holder of the tool. Insert the sport ball needle into the Presta valve adapter before attaching them to the adapter holder.

► **Fig.7:** 1. Sport ball needle 2. Presta valve adapter 3. Adapter holder 4. Tapered adapter

## Storing hose

The hose can be attached to the hose holder of the tool.

► **Fig.8:** 1. Hose holder 2. Hose

## Air release button

**NOTICE:** While the English valve adapter is attached to the tool, the air does not go out even when you press the air release button.

When the object is inflated too much, press the air release button to release air.

► **Fig.9:** 1. Air release button

## OPERATION

**NOTE:** The standard adapters vary depending on the country.

## Using the English valve adapter

**NOTICE:** Be sure to select the low speed mode when you inflate an object using an English valve adapter. If other mode is selected, the inflation cannot be performed properly.

1. Insert the English valve adapter into the air chuck.
2. Attach the English valve adapter to the valve stem while opening the English valve adapter.  
► **Fig.10:** 1. English valve adapter 2. Air chuck 3. Valve stem
3. Turn on the tool.
4. Inflate the tire by pulling the switch trigger while checking the status of the tire.

**NOTICE:** When using the English valve adapter, the pressure gauge will not display an accurate value due to characteristics of the valve. When inflating a tire, do not use the value on the pressure gauge, but inflate it by checking the status of the tire.

If the tool stops before the tire reaches the desired air pressure, adjust the pressure value, and then inflate the tire again.

## Using the Schrader valve adapter

1. Attach the air chuck to the valve stem.  
► **Fig.11:** 1. Valve stem 2. Air chuck
2. Turn on the tool, and then set the pressure value appropriate for the tire using the pressure gauge.
3. Keep pulling the switch trigger until the tool stops. The tire is inflated with the specified pressure.

## Using the Presta valve adapter

- Loosen the locking nut on the valve stem.  
▶ **Fig.12:** 1. Locking nut
- Attach the Presta valve adapter to the valve stem, and then attach the air chuck to the Presta valve adapter.  
▶ **Fig.13:** 1. Presta valve adapter 2. Valve stem 3. Air chuck
- Turn on the tool, and then set the pressure value appropriate for the tire using the pressure gauge.
- Keep pulling the switch trigger until the tool stops. The tire is inflated with the specified pressure.
- Remove the air chuck and Presta valve adapter, and then tighten the locking nut.

## Using the sport ball needle

**NOTICE:** Be sure to select the ball mode when you inflate a ball using a sport ball needle. If other mode is selected, the inflation cannot be performed properly.

To inflate sport balls, use the sport ball needle.

- Attach the sport ball needle to the air chuck.  
▶ **Fig.14:** 1. Air chuck 2. Sport ball needle
- Insert the sport ball needle into the hole on the ball.
- Turn on the tool.
- Set the inflation mode to the ball mode, and set the pressure value appropriate for the ball using the pressure gauge.
- Keep pulling the switch trigger until the tool stops. The ball is inflated with the specified pressure.

## Using the tapered adapter

**CAUTION:** Be careful not to inflate the floating tube too much.

To inflate floating tubes, use the tapered adapter.

- Attach the tapered adapter to the air chuck.  
▶ **Fig.15:** 1. Air chuck 2. Tapered adapter
- Insert the tapered adapter into the hole on the floating tube.
- Turn on the tool.
- Inflate the floating tube by pulling the switch trigger while checking the status of the floating tube.

**NOTICE:** When inflating a floating tube, do not refer to the current pressure value on the pressure gauge. The pressure gauge does not display an accurate current pressure value when the pressure of floating tube is less than 35 kPa (5 PSI).

## MAINTENANCE

**CAUTION:** Always be sure that the tool is switched off and the battery cartridge is removed before attempting to perform inspection or maintenance.

**NOTICE:** Never use gasoline, benzine, thinner, alcohol or the like. Discoloration, deformation or cracks may result.

To maintain product SAFETY and RELIABILITY, repairs, any other maintenance or adjustment should be performed by Makita Authorized or Factory Service Centers, always using Makita replacement parts.

## OPTIONAL ACCESSORIES

**CAUTION:** These accessories or attachments are recommended for use with your Makita tool specified in this manual. The use of any other accessories or attachments might present a risk of injury to persons. Only use accessory or attachment for its stated purpose.

If you need any assistance for more details regarding these accessories, ask your local Makita Service Center.

- Makita genuine battery and charger

**NOTE:** Some items in the list may be included in the tool package as standard accessories. They may differ from country to country.